

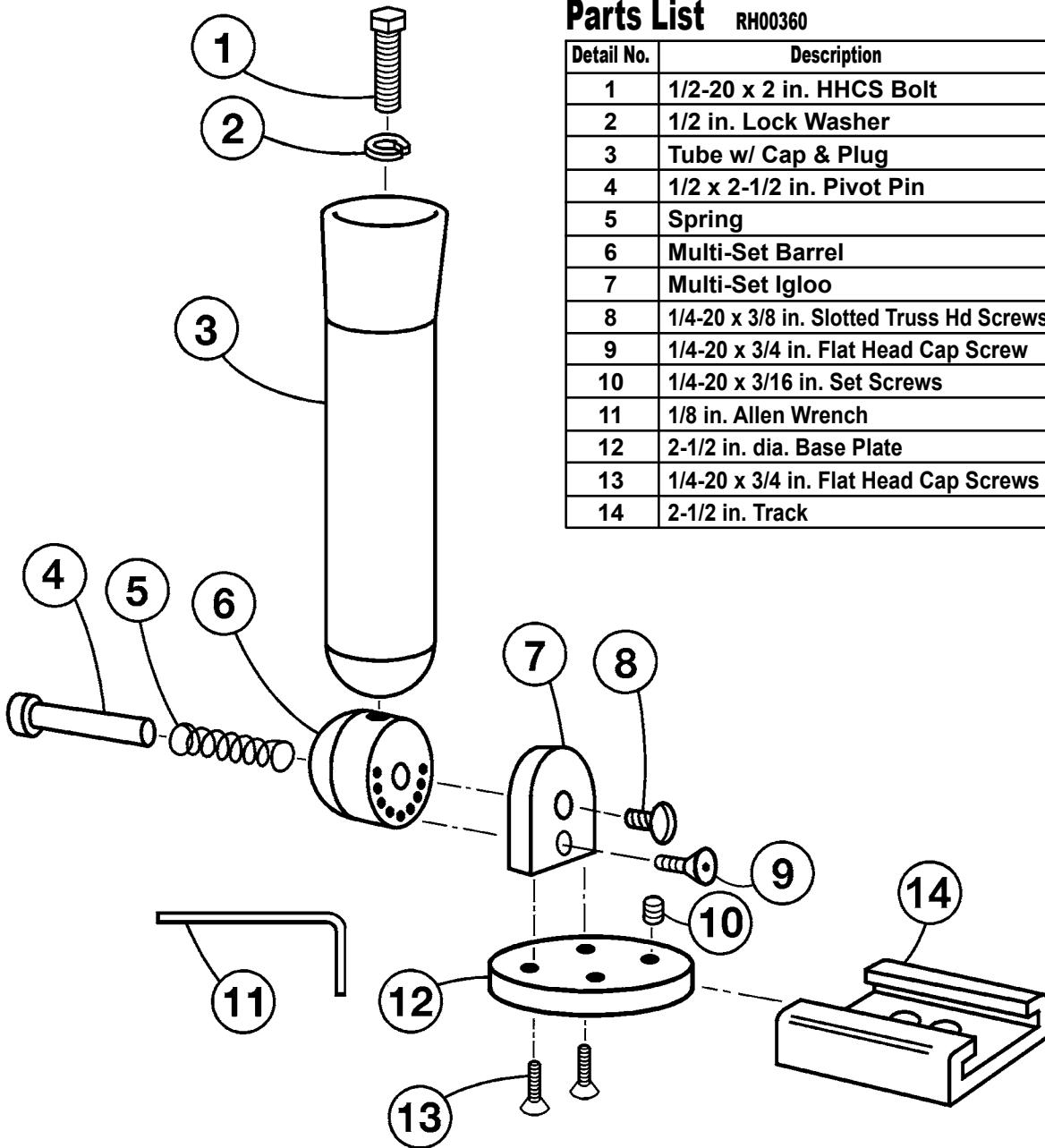

Multi-Axis Rod Holder

Parts List RH00360

Detail No.	Description	Qty.	Order By Part No.
1	1/2-20 x 2 in. HHCS Bolt	1	2351
2	1/2 in. Lock Washer	1	2241
3	Tube w/ Cap & Plug	1	51221
4	1/2 x 2-1/2 in. Pivot Pin	1	55555
5	Spring	1	2600
6	Multi-Set Barrel	1	55551
7	Multi-Set Igloo	1	55550
8	1/4-20 x 3/8 in. Slotted Truss Hd Screws	1	2158
9	1/4-20 x 3/4 in. Flat Head Cap Screw	1	2009
10	1/4-20 x 3/16 in. Set Screws	2	2261
11	1/8 in. Allen Wrench	1	2260
12	2-1/2 in. dia. Base Plate	1	55554
13	1/4-20 x 3/4 in. Flat Head Cap Screws	2	2009
14	2-1/2 in. Track	1	54024



Operating Instructions...

1. Hold the rod holder tube at the base and pull out from the locking pin.
2. Rotate the rod holder to any of the nine locking positions.
3. Reset the rod holder onto the locking pin.

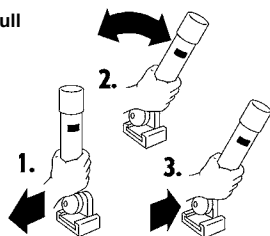

Mounting Instructions...

1. Make sure all wires below the mounting surface are clear of the area to be drilled.
2. Use the mounting channel as a template to locate and mark holes.
3. Drill the holes in the mounting surface and backing plate together.
4. Bolt the mounting base to the surface and backing board and secure with a flat washer and nut.

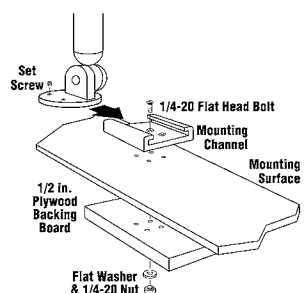

Big Jon Sports, Inc. • 11455 US-31 • Interlochen, MI 49643

(231) 275-1010 • Fax: (231) 275-1009 • email: emailus@bigjon.com • website: www.bigjon.com

Rev. No. 4 Revised: 9/30/15 By: PRL